

TRIODRIVE D/xS / MIDIDRIVE D/xS

Digital AC Servo Drives with Integrated Safety System

- For Direct Mains Connection to 230 V~ or 3 × 400/480 V~
- Motors up to 70 Nm/16 kW • Options for Communication:
- EtherCAT / Ethernet (TrioDrive D/ES and MidiDrive D/ES)
- Profibus Interface (TrioDrive D/PS and MidiDrive D/PS)
- CANopen[®] Interface (TrioDrive D/CS and MidiDrive D/CS)
- Analog Interface (TrioDrive D/AS and MidiDrive D/AS)



Components of the TrioDrive D/xS and MidiDrive D/xS servo drive families: MR 7476 (70 Nm at 2,000 r.p.m.), MR 7458 (24 Nm at 3,000 r.p.m.), MR 7436 (5.0 Nm at 6,000 r.p.m.), and MR 7411 (0.4 Nm at 6,000 r.p.m.) servo motors; MidiDrive D/CS servo drive 16 to 32 A, MidiDrive D/AS servo drive 2 to 8 A, and TrioDrive D/PS servo drive 0.8 to 6 A rated current

ESR Drive System Packages

ESR drive system packages consist of servo drives, optionally with field bus interface and position control, and servo motors with or without gearbox, complete with position sensors and, if required, brakes. They are supplemented by software and accessories.

For further information, see the back of this data sheet.

Applications

Positioning and feed movements with high dynamics and accuracy in

- Handling and assembly systems
- Electronics production machinery
- Semiconductor production machinery
- Measuring and testing machinery
- Machine tools and metal working machinery
- Packaging machinery
- Textile machinery
- Plastics processing machinery
- Coiling machinery
- and many other applications

Main Characteristics

Nine power classes

TrioDrive D/xS		Servo Motors	
I_N	U_{Zk}	M_N	P_N
0.8 A	320 V	up to 0.5 Nm	up to 0.2 kW
2 A	320 V	up to 1.5 Nm	up to 0.6 kW
4 A	320 V	up to 3.5 Nm	up to 1.3 kW
6 A	320 V	up to 5.5 Nm	up to 1.8 kW
MidiDrive D/xS		Servo Motors	
I_N	U_{Zk}	M_N	P_N
2 A	560 V	up to 3 Nm	up to 0.8 kW
4 A	560 V	up to 7 Nm	up to 1.8 kW
8 A	560 V	up to 17 Nm	up to 4.2 kW
16 A	560 V	up to 35 Nm	up to 8 kW
32 A	560 V	up to 70 Nm	up to 16 kW

Characteristics of the servo drives

- Compact device for control cabinet installation
- With power supply unit for direct connection to 230 V or 3 × 400/480 V AC (wide-range inputs)
- Integrated safety system, wear-free, two-channel (category 1-4 according to EN 954-1); PL e acc. to ISO 13849-1 or SIL 3 acc. to IEC 61800-2 in preparation
- Digital servo drive with 2 processors
- High dynamics and control quality due to signal processor for the digital control of current and speed (controller cycle time 62.5 μs)
- Position control (cycle time 1 ms, shorter cycle times on request) integrated
- Setting of the target positions via field bus (depending on the type) or positioning control with 500 blocks (option)
- Extensive technology functions, axis coupling (synchronization, electronic gearing, optionally flying shear) integrated
- Communication via field bus or RS 232C serial interface according to DRIVECOM Profile 22
- 8 digital inputs, 4 digital outputs
- 2 analog inputs, 2 analog outputs (option)
- Additional interfaces as an option (e. g. Modbus)
- Comfortable commissioning via PC
- Mains filter and shunt circuit integrated

- Easy wiring, as all connections can be plugged in at the front, at the top, or at the bottom
- UL certification in preparation

Characteristics of the servo motors

- Maintenance-free, since brushless
- High dynamics
- Wide speed control range
- IP 65 protection
- Insulation according to class F, DIN VDE 0530, withstanding tropical conditions
- High power-density due to rotor with rare earth permanent magnets
- Ball bearings with grease filling for 20,000 operating hours
- Integrated resolver for sinusoidal commutation, optionally optical position sensors (incremental or absolute, single- or multi-turn) for highest dynamics and accuracy
- Thermal protection by integrated PTC thermistor
- Connection of motor and position sensor via connectors
- Self-cooling
- Design with flange according to DIN 42 677, any mounting position
- Bearing plates and housings made of high-quality light-metal alloy
- Rotor dynamically balanced
- Standard shaft end without groove, special version possible, e. g. with keyway
- Special motors, e. g. short motors, hollow-shaft motors

The TrioDrive D/xS and MidiDrive D/xS servo drives can be operated as drive system packages with AC servo motors as well as with direct drives such as torque and linear motors.

All motors are described in detail in separate data sheets, for further information, see the back of this data sheet.

Characteristics of the optional gearboxes

- Single- or multi-stage planetary gears, low backlash on request, gear ratio 1 : 3 to 1 : 175
- Worm gear, ratio 1 : 6 to 1 : 208
- Output torques of up to 2400 Nm
- Special gearboxes, e.g. spur gear and bevel gearings, hollow-shaft gears

Type Code of the TrioDrive D/xS and MidiDrive D/xS Servo Drives

Example ⇒ **BN 67** **58** **4243** **B2** **R1** **A2** **F7** **K1** **S0**

↓

58

Mains connection and DC-bus voltage

TrioDrive D/xS: mains connection 230 V 1-phase, corresponds to 320 V DC-bus voltage

55 output current 0.8 A_{rms}
 56 output current 2 A_{rms}
 57 output current 4 A_{rms}
 58 output current 6 A_{rms}

MidiDrive D/xS: mains connection 400/480 V 3-phase, corresponds to 560/680 V DC-bus voltage

45 output current 2 A_{rms}
 46 output current 4 A_{rms}
 47 output current 8 A_{rms}
 48 output current 16 A_{rms}
 49 output current 32 A_{rms}

4243

Assembly code

Internal coding of ESR, given for various feature combinations. Statement of the assembly code is not required if all other features unequal zero are stated and the customer-specific equipment is described. For above-mentioned example, "BN 6758-B2-R1-A2-F7-K1" would be sufficient.

B2

Operating modes

B1 command mode with torque, speed or position control (standard); setting via communication interfaces
 B2 as B1, additionally program mode with positioning control, 500 blocks
 B3 as B1, additionally flying shear

R1

Motor position sensor

R1 resolver (standard)
 R2 Sincos (Hiperface) encoder (single- or multi-turn)
 R3 high-resolution incremental encoder Heidenhain ERN 1185 or ERN 1387
 R4 EnDat encoder 2.1 (single- or multi-turn)
 R5 incremental encoder (square-wave signals RS 422)
 R7 BiSS encoder (single- or multi-turn)
 RK customer-specific

A2

Digital and analog inputs/outputs

A1 8 digital inputs, 4 digital outputs (24 V); 2 analog inputs, 2 analog outputs (±10 V)
 A2 8 digital inputs, 4 digital outputs (24 V); no analog inputs/outputs (standard)

F7

Fieldbus connection, output encoder signals, or input encoder signals

(Options Fx, Gx, and Lx exclude each other)

Field bus connection

F2 CANopen® (standard for TrioDrive D/CS and MidiDrive D/CS)
 F5 Profibus DP (standard for TrioDrive D/PS and MidiDrive D/PS)
 F7 EtherCAT (standard for TrioDrive D/ES and MidiDrive D/ES)
 F8 Ethernet interface for TCP/IP communication (protocols Modbus/TCP, ESR; others on request) (option for TrioDrive D/ES and MidiDrive D/ES)

Output encoder signals (encoder emulation)

G0 none (option for TrioDrive D/AS and MidiDrive D/AS)
 G1 incremental encoder output 5 V, push-pull signals RS 422 (standard for TrioDrive D/AS and MidiDrive D/AS)

Input encoder signals for axis coupling (synchronization, electronic gearing, flying shear), external position sensor or pilot frequency; incremental encoder signals (pulse/direction signals on request)

L1 signal level 5 V, push-pull signals RS 422 (TrioDrive D/AS and MidiDrive D/AS only)

ZL1

Additional interface (optional)

ZG1 incremental encoder output 5 V, push-pull signals RS 422
 ZL1 input encoder signals 5 V, push-pull signals RS 422
 ZL4 additional EnDat interface for external position sensor (EnDat 2.1, single- and multiturn, V 2.2 on request)
 ZL7 additional BiSS interface for external position sensor (BiSS, single- and multiturn)
 ZF2 additional CAN interface for the connection of additional peripheral devices
 ZF8 additional COM interface for serial Modbus (RS 232/RS 422/RS 485, protocols RTU, ASCII)
 ZK additional interface, customer-specific

K1

Safety system

K1 integrated safety system, safe standstill (STO) (standard)

S0

Special equipment

S0 none (standard)
 SK customer-specific

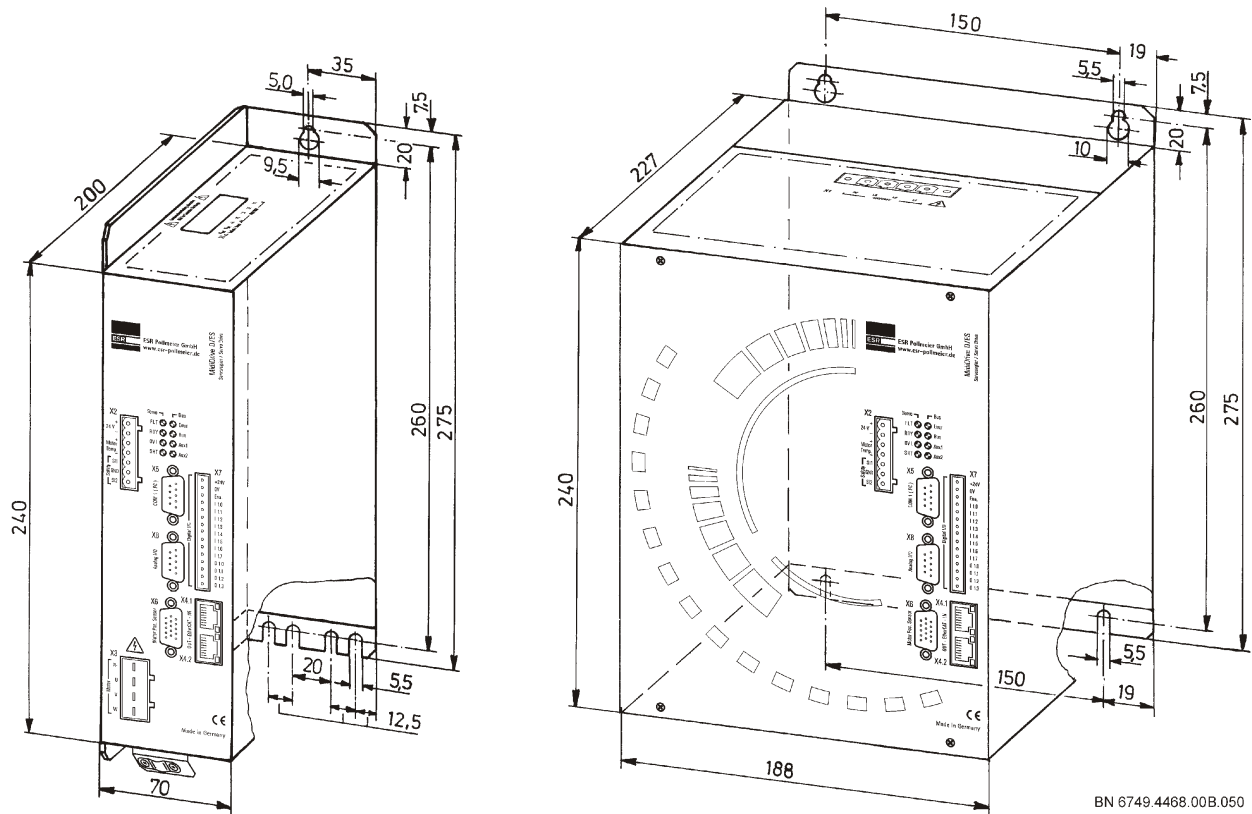

Figure 1: Dimensions MidiDrive D/xS (in mm): to the left device with 2 to 8 A, to the right device with 16 and 32 A rated current

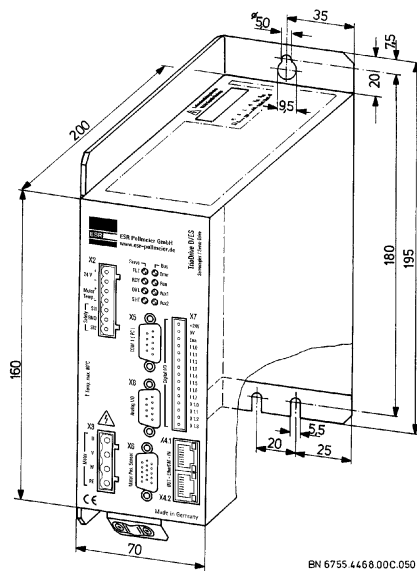

Figure 2: Dimensions TrioDrive D/xS (in mm)

Servo Drives

Enclosure and installation

TrioDrive D/xS and MidiDrive D/xS servo drives are compact devices for installation in control cabinets. To avoid radiated emissions, the enclosure is made of stainless steel and aluminum. Since the enclosure is not varnished, all metal parts have best electrical contact to each other.

Power supply unit

The power supply unit is integrated. The power unit is fed directly by the mains (230 V AC or 3 × 400/480 V AC). For the control unit, a control supply voltage of 24 V has to be supplied. The power supply unit contains a RFI filter as well as a shunt regulator. The shunt resistor of this regulator absorbs the energy fed back when the motor is braked. An externally mounted shunt resistor can be connected, as well.

Interfaces of the servo drives

LEDs are provided at the front panel. All connections can be plugged at the front panel, the top side and, for devices with higher power, at the bottom side. Combicon connectors are available for the easy connection of:

- power supply and external shunt resistor
- motor
- control supply voltage 24 V
- protective earth PE
- safety system

Depending on the application, the following can be connected additionally via the Combicon connectors:

- 8 digital inputs and 4 digital outputs
- motor temperature sensor (if not connected via the connector of the motor position sensor)

D sub connectors are provided at the front panel for the connection of:

- motor position sensor (resolver as standard, optionally optical motor position sensors, see type code on the last page of this data sheet)
- COM1 (RS 232C) for connecting a PC
- analog inputs and outputs (partly optional)
- input or output encoder signals (Trio- and Midi-Drive D/AS)

Input encoder signals is provided for axis coupling (synchronization, electronic gearing, flying shear), external position sensor, or pilot frequency mode; output encoder signals for encoder emulation.

Devices with option -Fx are equipped with a field bus interface at the front panel:

- Trio- and MidiDrive D/ES (option -F7 or -F8): two RJ-45 connectors for connecting EtherCAT or Ethernet
- Trio- and MidiDrive D/PS (option -F5): one D sub connector for connecting Profibus DP
- Trio- and MidiDrive D/CS (option -F2): two RJ-45 connectors for connecting CANopen®

Depending on the equipment, an optional additional interface can be installed at the top:

- additional incremental encoder output (option -ZG1)
- additional input encoder signals (option -ZL1)

- additional EnDat interface (option -ZL4)
- additional BiSS interface (option -ZF7)
- additional CAN interface (option -ZF2)
- additional Modbus interface (option -ZF8)

If required, we also supply connection cables (ready-assembled, as well), connector sets, and other accessories. For further information, see data sheet 8817.201 "Accessories".

Servo Motors

Design of the servo motors, resolver / encoder systems

The servo motors described here are permanent-magnet three-phase synchronous motors. The stator carries the 3-phase winding, the rotor is equipped with rare earth magnets at its surface. As the winding is located in the stator, the heat developing there can easily be dissipated via the surface. As standard, the motors are delivered for flange mounting.

The standard position sensor of the motors is a resolver. For applications with particularly high requirements to the positioning accuracy, an optical motor position sensor with 512, 1024, or 2048 sine periods (system accuracy $\pm 60''$ to $\pm 20''$) or an incremental encoder (square-wave signals) with 1024, 2048, or 4096 pulses (system accuracy $\pm 64''$ to $\pm 16''$) can be used instead of a resolver (system accuracy $\pm 15''$).

For further information on the motor position sensor, see the type code of the servo drive on page 3 of this data sheet as well as the data sheets for the servo motors.

For protection against overheating, the motors are equipped with a temperature sensor which is evaluated in the servo drive.

The connection of motor and position sensor is done via connectors.

Detailed information on the motors can be found in separate data sheets and in the internet on www.esr-pollmeier.de.

Direct drive systems

The TrioDrive D/xS and MidiDrive D/xS servo drives can also be used for operating direct drives such as torque or linear motors. Our corresponding product range can be found in the internet on www.esr-pollmeier.de.

Motor accessories

- Brakes
 - Permanent magnet brake or spring brake, designed as holding brake; occasional load braking, e. g. in case of an emergency stop, is permitted.

Control and Monitoring

Digital control loops

All control loops for current (corresponds to the torque), speed, and position work fully digitally. Thus, the servo drive is drift-free. All settings can be archived and reproduced via PC software SPP Windows.

A signal processor controls current, speed, and power circuit. With a cycle time of only 62.5 μ s, the control algorithms ensure high dynamics and a high control quality. The position control runs in a 16 bit microcontroller and operates at a cycle time of 1 ms (shorter cycle times on request).

Safety system

The wear-free electronic solution for "safe standstill" (STO, stop category 0) developed by ESR is used in the TrioDrive D/xS and MidiDrive D/xS servo drives. Due to the two-channel design (safety category 4, includes categories 1, 2, and 3), an evaluation is not required on the controller side.

Fig. 3 shows an example of a common safety circuit (A). Compared to that, many switching components such as line contactors etc. are not needed with the TrioDrive D/xS and MidiDrive D/xS safety circuit (B).

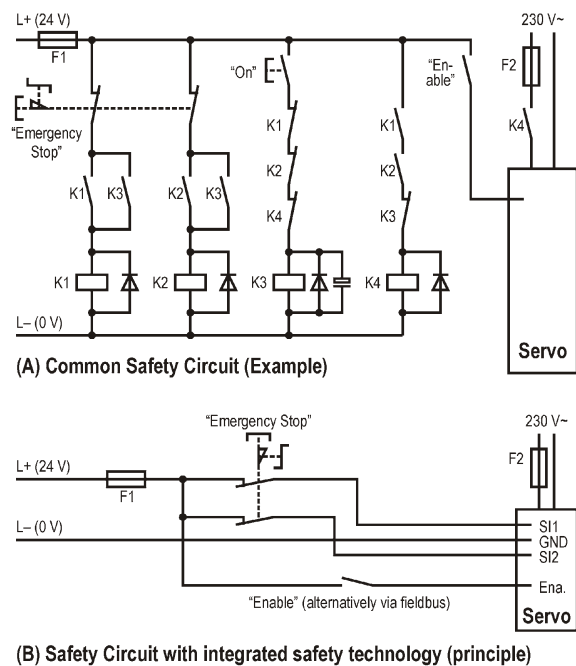

Figure 3: Example of a Safety Circuit

A safety switching device, e. g. PNOZe1p by Pilz, with transistor outputs can be connected. This device additionally monitors the safety wiring within the control cabinet for earth fault and short circuits across input contacts using so-called OSSD signals (Output Signal Switching Device).

Monitoring functions

The TrioDrive D/xS and MidiDrive D/xS servo drives are equipped with several monitoring functions which ensure trouble-free operation even in case of external faults.

The drives are equipped with protective circuits against e. g.

- short circuit between motor phases
- earth leakage of one or several motor phases
- overtemperature of drive and motor
- mains overvoltage
- faults in the resolver voltages
- blocking of the motor
- mains voltage failure or shutoff
- different voltages at the safety inputs

These or other faults are stored. If the cause of the fault has been eliminated, the motor cannot run unless the fault memory has been reset from outside.

The following functions have been realized for the monitoring or protection of the machine:

- limit switch functions
- I²t current limiting

Functions of the Servo Drives

Operating modes

TrioDrive D/xS and MidiDrive D/xS servo drives can be used in a wide range of applications. For that, different operating modes such as torque mode, target position mode, or program mode can be selected via software. There are two large groups of operating modes:

- command mode and
- program mode (option)

Command mode

In command mode, individual movements can be specified via different interfaces. In this mode, the following axis operating modes are available as sub-modes:

- torque mode
- velocity mode
- target position mode,
- homing mode,
- electronic gearing,
- flying shear

In these axis operating modes, depending on the device, one of the following interfaces can be selected as setpoint source:

- EtherCAT or Ethernet interface
- Profibus interface
- CANopen[®] interface
- analog input (axis operating modes torque and velocity mode)
- input encoder signals (optional) (axis operating modes electronic gearing, flying shear)
- COM1 (RS 232C) serial interface
- Modbus (option) (RS 232 / RS 422 / RS 485)

The behavior of the drive in the different axis operating modes can be adapted to the application via machine data. Thus, e. g. acceleration and deceleration ramps can be set independent of each other (with trapezoidal or sin²(t) ramps, if required).

Program mode

The program mode is available as an option. For that, a positioning control is integrated into the device running a part program which can communicate with other controls via various interfaces. This can be used to integrate the drive in the overall function of the machine. The part programs consist of single lines, also called blocks. The part program memory has a capacity of 500 blocks on which any number of part programs can be distributed.

The block type determines the function of the individual block. Essential block types in the part program are:

- positioning
- feedforward
- machine functions (set outputs)
- going to home position
- jump to label
- jump on input (bit pattern)
- wait for input (bit pattern)
- program part repetition
- jump to/return from subroutine

The values for positions, speeds, etc. can either be defined directly in the block or via variables which can be changed at any time via the communication interfaces.

Part programs can be written comfortably with the SPP Windows software.

Machine data

The parameters of the drive are set via so-called machine data. These data are stored in the servo drive in a way that they are protected against power failure. The machine data include e. g.:

- axis type (linear, round, continuous)
- motion profile type (linear, sin²) and slope
- factors for adapting position and speed values to physical units, e. g. μm, m/min
- control-loop parameters
- software limit switches
- in-position window
- behavior of control outputs

Most machine data can be changed during operation via the communication interfaces, e. g. for adapting ramps or controllers to different operating conditions.

Communication

Field bus (EtherCAT, Ethernet, Profibus DP, or CANopen®)

The Trio- and MidiDrive D/ES, D/PS, and D/CS servo drives are equipped with a field bus interface. All parameters of the servo drive can be transmitted via this interface:

- control and status information
- setpoints and actual values
- machine data
- part programs
- variables

The dynamically changing parameters (control and status information, rated and actual values) are transmitted cyclically via the process data channel. The other parameters are transmitted via the parameter channel.

EtherCAT or Ethernet interface

The Trio- and MidiDrive D/ES servo drives are equipped with an EtherCAT interface.

The XML files for these devices can be downloaded from www.esr-pollmeier.de (see download area).

Optionally, these devices can be equipped with an Ethernet interface for TCP/IP communication (protocols Modbus/TCP and ESR, others on request).

Profibus DP interface

The Trio- and MidiDrive D/PS servo drives are equipped with a Profibus DP interface. For sending and receiving, up to 16 bytes are available in the process data channel.

The GSD file for these devices can be downloaded from www.esr-pollmeier.de (see download area).

CANopen® interface

The Trio- and MidiDrive D/CS servo drives are equipped with a CANopen® interface.

The EDS file for these devices can be created with SPP Windows.

DRIVECOM profile 22 and CiA® 402

Common parameters of a positioning drive were standardized by the DRIVECOM user group in profile 22 and by CAN in Automation (CiA®) in drive profile CiA 402. ESR was actively involved in the development of these standards, and the Trio- and MidiDrive D/xS servo drives have been developed according to these profiles. The DRIVECOM profile 22 is used for all fieldbus interfaces. This guarantees a standardized parameter access independent of the bus system.

Serial interface and Modbus

All parameters of the drive can be transmitted via the serial interface (RS 232C or Modbus RS 232 / RS 422 / RS 485, see below). For that, the DRIVECOM profile 22 parameters are used there, as well. Therefore, users working only with the serial interface at the beginning can make use of the knowledge acquired there in case of a future application of a fieldbus.

Analog interface

The Trio- and MidiDrive D/AS servo drives are equipped with an analog interface. These devices are particularly suitable for multi-axis applications with higher-level controller (CNC) or as master and slave axis in synchronization applications (axis coupling).

Additional interfaces

In addition to the standard communication interfaces, all Trio- and MidiDrive D/xS can be equipped with an additional interface (e. g. Modbus) for connecting other peripheral devices.

Commissioning and Software

The servo drives are delivered ready for operation. For commissioning, a PC can be connected via serial interface COM1. Alternatively, the PC can be connected via the fieldbus interface; for information on PC connection modules, please contact ESR.

Command and commissioning software SPP Windows

For easy operation and commissioning of the servo drives using a PC: input and modification of ma-

chine data and part programs, control of the drives in all operating mode for commissioning purposes. Control-loop parameters can be set comfortably using oscilloscope functions. Options for archiving and documenting data complete the scope of functions.

For detailed information, see data sheet 6710.260 "Software for Servo Drives".

Function blocks

For an easy integration of the servo drives into automation systems with Simatic S7 and compatible controllers as well as controllers programmed according to IEC 61131-3, e. g. Beckhoff TwinCAT, other controllers on request. (For a list of supported controllers, see www.esr-pollmeier.de, "Products / Software".)

The function blocks are based on PLCopen specification "Function blocks for motion control".

Supported functions:

- parameterization of the servo drives by the controller (e. g. after switch-on)
- triggering of movements (relative/absolute positioning, going to home position, speed setting ...)
- influencing the positioning control integrated in the drive (part program)
- input and output of binary signals (software inputs/outputs)
- example programs for using the function library as a basis for the development of own programs

For further information on our software products, please see Data Sheet 6710.260 "Software for Servo Drives".

Drivers and DLL libraries

Drivers and DLL libraries are available for developing own application programs under Windows. Example programs with documented source code can be used as a basis for the development of own programs.

For further information on our software products, please see Data Sheet 6710.260 "Software for Servo Drives".

Accessories

- Motor supply cables and encoder connection cables (also available as ready-assembled cables)
- Motor chokes (for long motor supply cables)
- Connector sets consisting of D sub male or female connectors, including screwable housings, and the Combicon connectors
- Field bus connection cables
- External shunt resistor (for special applications in which the internal shunt resistor is not sufficient)

For further information on connection cables, cables, and other accessories, see data sheet 8817.201 "Accessories".

For further information on our software products, please see Data Sheet 6710.260 "Software for Servo Drives".

Type codes of the servo motors

are included in the separate data sheets of the corresponding motors, they are also available in the internet on www.esr-pollmeier.de.

Detailed information on ESR products and the corresponding accessories is also available in the internet on www.esr-pollmeier.de.

TrioDrive D/xS Servo Drives, Main Technical Specifications and Order Numbers

Servo Drive	TrioDrive D/xS			
	BN 6755	BN 6756	BN 6757	BN 6758*
Rated supply voltage	230 V AC $\pm 10\%$, 50 .. 60 Hz			
Rated DC-bus voltage	320 V DC			
Permissible supply voltage	85 .. 253 V AC (corresponds to 115 .. 340 V DC-bus voltage)			
Rated current (rms)	0.8 A	2 A	4 A	6 A
Pulse current (crest value)	3.4 A	8.5 A	17 A	25.5 A
Rated electrical power	0.3 kVA	0.75 kVA	1.5 kVA	2.1 kVA
Efficiency**	94.2%	96.0%	97.2%	97.6%
Switching frequency of power circuit	16 kHz			
Control supply voltage	24 V DC $\pm 20\%$, 0.4 A			
Safety system inputs	24 V DC $\pm 20\%$, 2 x 0.1 A			
Width x Height x Depth***	70 mm x 195 mm x 200 mm			
Weight	1.6 kg			

* Drive BN 6758 (6 A device) may be operated up to a loading of 70% without restrictions. For a higher loading, the device must be installed next to a control cabinet fan or equipped with a sub-assembled fan.

** in rated operation

*** without connectors

TrioDrive D/xS Drive System Packages (Selection), Main Technical Specifications, Order Numbers

In addition to the motors listed below, a variety of other motors are available. Detailed information can be found in separate data sheets and in the internet on www.esr-pollmeier.de.

Flange Dimension (mm)	Order Number Motor	Speed (rpm)	Rated Torque (Nm)	Stall Torque (Nm)	Peak Torque (Nm)	Shaft Power (kW)	Order Number Drive
37	MR 7401-U3-N060	6000	0.1	0.1	0.4	0.6	BN 6755
55	MR 7411-U3-N060	6000	0.4	0.5	2.0	0.2	BN 6756
	MR 7414-U3-N060	6000	1.4	1.6	6.4	0.9	BN 6757
70	MR 7422-U3-N034	3400	1.6	1.8	8.0	0.6	BN 6757
	MR 7424-U3-N034	3400	2.7	3.1	12.7	1.0	BN 6758
90	MR 7434-U3-N034	3400	3.6	4.8	appr. 10.0	1.3	BN 6758

The rated torques refer to the stated speed. At lower speeds, the torques are higher. We recommend to choose the best combination for your application together with us. We will be pleased to calculate and configure the drive system.

MidiDrive D/xS Servo Drives, Main Technical Specifications and Order Numbers

Servo Drive	MidiDrive D/xS				
	BN 6745	BN 6746	BN 6747*	BN 6748	BN 6749*
Rated supply voltage	3 × 400/480 V AC ±10%, 50 .. 60 Hz				
Rated DC-bus voltage	560/680 V DC				
Permissible supply voltage	90 .. 528 V AC (corresponds to 125 .. 740 V DC-bus voltage)				
Rated current (rms)	2 A	4 A	8 A	16 A	32 A
Pulse current (crest value)	5.5 A	11 A	22 A	45 A	90 A
Rated electrical power	1.4 kVA	2.7 kVA	5.5 kVA	11 kVA	22 kVA
Efficiency**	96.7%	97.3%	97.8%	97.7%	97.9%
Switching frequency of power circuit	8 or 16 kHz (to be selected)				
Control supply voltage	24 V DC ±20%, 0.5 A			24 V DC ±20%, 1.1 A	
Safety system inputs	24 V DC ±20%, 2 × 0.1 A			24 V DC ±20%, 2 × 0.15 A	
Width × Height × Depth***	70 mm × 275 mm × 200 mm			190 mm × 275 mm × 227 mm	
Weight	2.8 kg			10.0 kg	

* BN 6747 (8 A devices) and BN 6749 (32 A devices) servo drives may be operated at a power circuit switching frequency of 8 kHz without restrictions. With 16 kHz, the rated current is reduced to 6 A or 16 A (rms) and the pulse current to 22 A or 45 A (crest value).

** at 8 kHz, in rated operation

*** without connectors

MidiDrive D/xS Drive System Packages (Selection), Main Technical Specifications, Order Numbers

In addition to the motors listed below, a variety of other motors are available. Detailed information can be found in separate data sheets and in the internet on www.esr-pollmeier.de.

Flange Dimension (mm)	Order Number Motor	Speed (rpm)	Rated Torque (Nm)	Stall Torque (Nm)	Peak Torque (Nm)	Shaft Power (kW)	Order Number Drive
55	MR 7411-U5-N060	6000	0.4	0.5	2.0	0.2	BN 6745
70	MR 7422-U5-N060	6000	1.6	1.8	8.0	1.0	BN 6746
87	MR 7436-U5-N060	6000	5.0	6.8	appr. 10	3.3	BN 6747
115	MR 7444-U5-N030	3000	8.0	10.0	appr. 20	2.5	BN 6747
140	MR 7454-U5-N030	3000	13.0	15.0	appr. 40	4.1	BN 6748
190	MR 7467-U5-N030	3000	26.0	40.0	appr. 97	8.2	BN 6749
225	MR 7476-U5-N020	2000	70.0	93.0	appr. 156	15.0	BN 6749

The rated torques refer to the stated speed. At lower speeds, the torques are higher. We recommend to choose the best combination for your application together with us. We will be pleased to calculate and configure the drive system.

Servo Drive System Packages by ESR Pollmeier GmbH

ESR – the complete servo drive system from a single source

General

The servo drives described in this data sheet are components of the ESR drive system packages. These consist of servo drives and servo motors with or without gearboxes, completely with position sensors and, if required, brakes. They are supplemented by software and accessories. All parts of the packages are matching and have been tested as combinations. This delivery from one single source guarantees trouble-free commissioning, reliable operation, and a definite system responsibility on the part of only one supplier.

System design

Our services include an individual drive system configuration. With many years of experience, we will be pleased to assist you at choosing the appropriate servo drive system for your application.

Drive system packages

The following drive system packages are available on the basis of the series TrioDrive D/xS and MidiDrive D/xS servo drives:

AC Servo Motors	MR 74	MR 75	MR 77	MR 6
Protection class	IP 65	IP 54 (without housing)	IP 54 (IP 65 optional)	IP 54 (IP 65 optional)
Flange dimension	37 .. 240 mm	55 .. 140 mm	40 .. 188 mm	37 .. 190 mm
Rated speed	2,000 .. 6,000 r.p.m.	3,000 r.p.m.	1,000 .. 8,000 r.p.m.	2,000 .. 7,000 r.p.m.
Rated torque	0.1 .. 70 Nm	0.4 .. 33 Nm	0.2 .. 43.5 Nm	0.05 .. 23 Nm
Stall torque	0.1 .. 115 Nm	0.5 .. 45 Nm	0.2 .. 53 Nm	0.1 .. 32 Nm
Shaft power	0.05 .. 15.7 kW	0.15 .. 10.5 kW	0.14 .. 7.5 kW	0.04 .. 7.2 kW
Data sheet	6674.260	6675.260	6677.260	6612.264

Torque Motors	MH 4	MH 1
Protection class	IP 54 (IP 65 optional)	IP 40 (IP 67 optional)
Flange dimension	140 .. 250 mm	200 .. 300 mm
Rated speed	250 .. 500 r.p.m.	120 .. 700 r.p.m.
Rated torque	14 .. 270 Nm	10 .. 150 Nm
Shaft power	0.7 .. 7.1 kW	0.7 .. 3.9 kW
Data sheet	6700.274	6700.271

Linear Motors	ML 11 to ML 14	ML 15 to ML 17
Type	with iron	iron-free
Continuous power	60 .. 4,700 N	20 .. 560 N
Peak power	120 .. 8,500 N	100 .. 2.160 N
Max. speed	2.5 .. 10 m/s	2.7 .. 18 m/s
Data sheet	6700.261	6700.261

The statements in this data sheet are for information, only. They do not guarantee properties. We reserve the right to make changes without notice. ESR is a registered trade mark of ESR Pollmeier GmbH. All software and hardware brands and names mentioned here are trademarks or registered trademarks of their respective holders and are generally subject to trademark, registered trademark, or patent protection.