

TRIODRIVE D SERVO DRIVES

Digital AC Servo Drives with Direct Mains Connection
230 V AC • Motors up to 5 Nm / 1.5 kW
Integrated Positioning Control (Option)

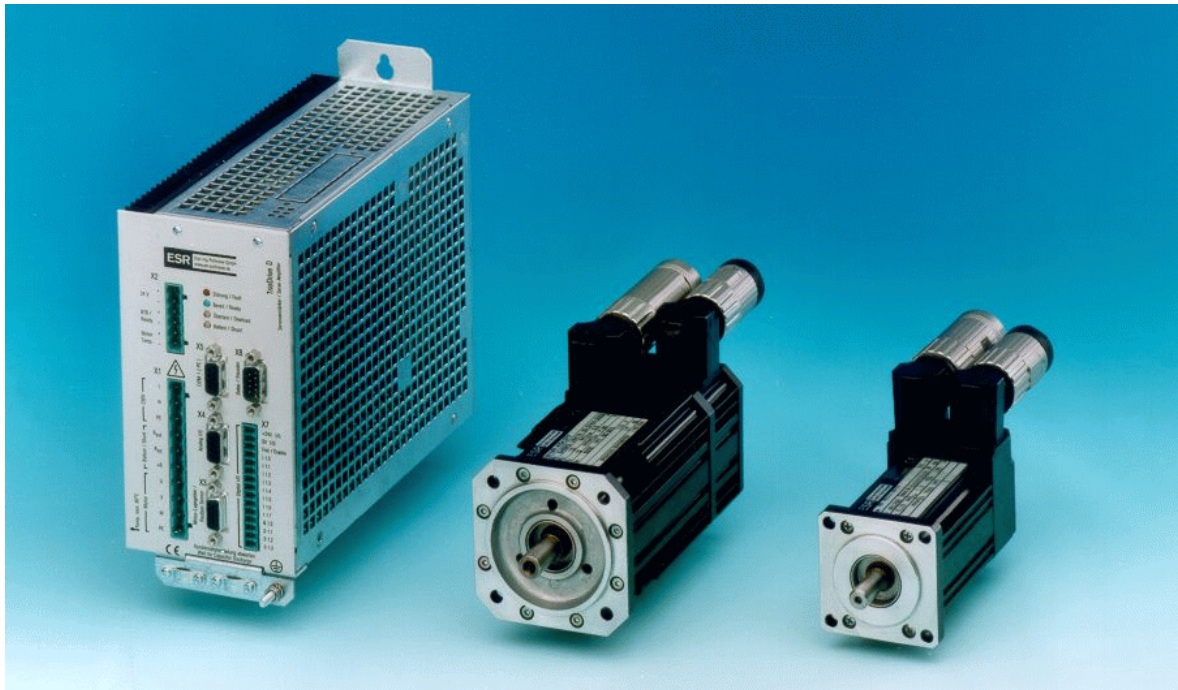

Components of the TrioDrive D servo drives family: BN 6752 servo amplifier of medium power (4 A); MR 4104 motor (0.5 Nm at 6000 r.p.m.), MR 4030 motor (0.3 Nm at 6000 r.p.m.)

Products, Consultation, Service

ESR drive packages consist of servo amplifiers, optionally with fieldbus interface and positioning control, and servo motors with or without gearboxes, completely with position sensors and, if required, brakes. They are supplemented by software and accessories. All parts of the packages are matching and have been tested as combinations. This delivery from a single source guarantees trouble-free commissioning, reliable operation, and a definite system responsibility on the part of only one supplier.

Our services include an individual drive system configuration. With many years of experience, we will be pleased to assist you at choosing the appropriate servo drive for your application.

Applications

Positioning and feed movements with high dynamics and accuracy in

- handling and assembly systems
- optical discs production machines
- packaging machines
- textile machines
- plastics processing machines
- coiling machines
- flame cutting machines
- measuring and testing machines
- electronics production machines
- ...

Main Characteristics

Three power classes

Servo amplifiers		Servo motors	
I_N	U_{Zk}	M_N	P_N
2 A	320 V	up to 1.0 Nm	up to 0.5 kW
4 A	320 V	up to 3.5 Nm	up to 0.7 kW
6 A	320 V	up to 5.0 Nm	up to 1.1 kW

Characteristics of the MR 4 servo motors

- Maintenance-free, since brushless
- High dynamics
- Wide speed control range
- IP 65 protection
- Insulation according to class F, DIN VDE 0530, withstanding tropical conditions
- High power-density due to rotor with rare earth permanent magnets
- Ball bearings with grease filling for 20,000 operating hours
- Integrated resolver for sinusoidal commutation, optionally optical position sensors (incremental or absolute, single- or multi-turn) for highest dynamics and accuracy
- Thermal protection by integrated PTC thermistor
- Connection of motor and position sensor via connectors (higher powers via terminal box)
- Self-cooling, cooling by mounted fan on request
- Design with flange according to DIN 42 677, any mounting position
- Construction type according to DIN IEC 34 part 7, IM B 5, IM B 35
- Bearing plates and housings made of high-quality light-metal alloy
- Rotor dynamically balanced according to vibration severity grade R, S on request
- Standard shaft end without groove, special version possible, e. g. with keyway
- Special motors, e. g. short motors, hollow-shaft motors

Characteristics of the optional gearboxes

- Single- or multi-stage planetary gears, low backlash on request, gear ratio 1 : 3 to 1 : 175
- Worm gear, ratio 1 : 6 to 1 : 208

- Output torques of up to 2400 Nm
- Special gearboxes, e.g. spur gear and bevel gearings, hollow-shaft gears

Characteristics of the TrioDrive D servo amplifiers

- Compact amplifier for control cabinet installation
- Complete with power supply unit for direct connection to 230 V AC
- Digital servo amplifier with 2 processors
- High dynamics and control quality due to signal processor for the digital control of current and speed (controller cycle time 62.5 μ s)
- Technology functions for which additional external controls used to be necessary are now integrated in the servo amplifier by 16 bit microcontroller
- Position control (cycle time 1 ms) integrated, setting of the target positions via communication interfaces (standard) or positioning control with 500 blocks (option)
- 8 digital inputs, 4 digital outputs
- Axis coupling (synchronization, electronic gearing, and optionally flying shear) integrated
- Standard communication via serial interface RS 232C (RS 485 as an alternative), optionally via Interbus, CANopen, or Profibus DP according to DRIVECOM profile 22
- Easy wiring, as all connections can be plugged in at the front and at the top
- Comfortable commissioning via PC
- Construction in conformance with EMC requirements (CE marking)

Servo Motors

Design of the servo motors, resolver / encoder systems

The servo motors described here are permanent-magnet three-phase synchronous motors. The stator carries the 3-phase winding, the rotor is equipped with rare earth magnets at its surface. As the winding is located in the stator, the heat developing there can easily be dissipated via the surface. As standard, the motors are delivered for flange mounting.

The standard position sensor of the motors is a two-pole brushless hollow-shaft resolver. For applica-

tions with particularly high requirements to the positioning accuracy, a high-resolution incremental encoder, a Sincos (Hiperface) encoder, or an EnDat encoder can be installed, optionally. For protection against overheating, the motors are equipped with a temperature sensor which is evaluated in the servo amplifier.

The connection of motor and position sensor is done via connectors (higher powers via terminal box).

Detailed information on the motors can be found in separate data sheets and in the internet on www.esr-pollmeier.de.

Motor accessories

- Brakes
 - Permanent magnet brake, designed as holding brake; occasional load braking, e. g. in case of an emergency stop, is permitted.
- External fans
 - For external cooling, mounted fans are available. They are used when the motor power has to be increased without changing the size of the motor.

Servo Amplifiers

Enclosure and installation

TrioDrive D servo amplifiers are compact amplifiers for installation in control cabinets. To avoid radiated emissions, the enclosure is made of zinc-plated sheet steel. Since the enclosure is not varnished, all metal parts have best electrical contact to each other.

Power supply unit

The power supply unit is integrated. The power unit is fed directly by the 230 V AC mains. For the control unit, a control supply voltage of 24 V is supplied. The power supply unit contains a RFI filter as well as a shunt regulator. The shunt resistor of this regulator absorbs the energy fed back when the motor is braked. An externally mounted shunt resistor can be connected, as well.

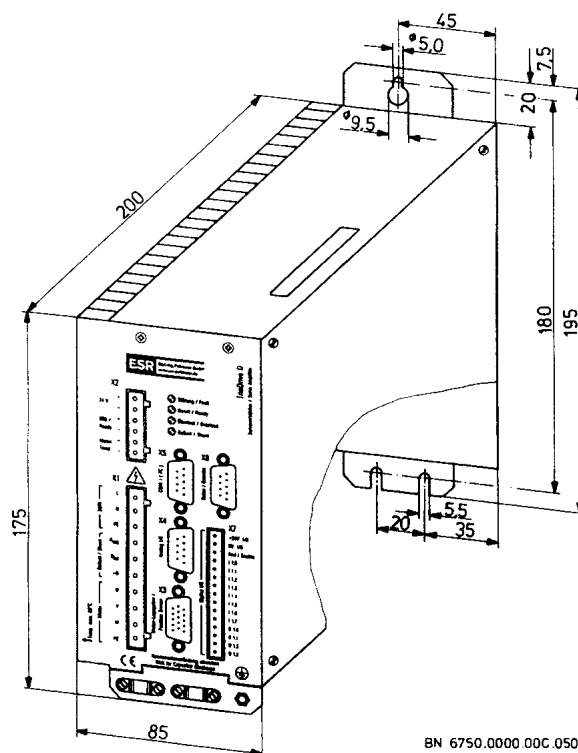

BN 6750.0000 00C.050

Figure 1: Dimensions (mm)

Interfaces of the servo amplifier

All connections are made from the front or the top. Combicon connectors are provided at the front panel for the easy connection of:

- mains power supply
- motor
- control supply voltage 24 V
- protective earth PE (additionally via screw bolt)

Depending on the application, the following can be connected additionally via the Combicon connectors:

- "BTB/Ready" output (relay contact)
- 8 digital inputs and 4 digital outputs
- additional external shunt resistor
- motor temperature sensor (if not connected via the connector of the motor position sensor)

SUB-D connectors are provided at the front panel for the connection of:

- motor position sensor (resolver as standard, optionally high-resolution incremental encoder, Sincos (Hiperface) encoder, or EnDat encoder)
- input or output encoder signals (option)

Input encoder signals is provided for axis coupling (synchronization, electronic gearing, flying shear), external position sensor, or pilot frequency; output encoder signals for incremental encoder emulation

- COM1 (RS 232C, optionally RS 485) for connecting a personal computer
- analog signals (2 setpoint inputs, 2 monitoring outputs)

Connectors for the fieldbus interface (optional) are located on the top:

- Interbus according to DRIVECOM profile 22
- CAN bus according to CANopen standards and DRIVECOM profile 22
- Profibus DP according to DRIVECOM profile 22

The four LEDs "Ready", "Overload", "Shunt", and "Fault" are located on the front panel.

Control and Monitoring

Digital control loops

All control loops for current (corresponds to the torque), speed, and position work fully digitally. Thus, the servo amplifier is drift-free. All settings can be archived and reproduced via PC software SPP Windows.

A signal processor controls current, speed, and power circuit. With a cycle time of only 62.5 μ s, the control algorithms ensure high dynamics and a high control quality. The position control runs in a 16 bit microcontroller and operates at a cycle time of 1 ms. An external position sensor can be used for particularly accurate positionings.

Monitoring functions

The TrioDrive D servo amplifiers are equipped with several monitoring functions which ensure trouble-free operation even in case of external faults.

The amplifiers are equipped with protective circuits against e. g.

- short circuit between motor phases
- earth leakage of one or several motor phases
- overtemperature of amplifier and motor
- mains overvoltage
- faults in the resolver voltages
- blocking of the motor

- mains voltage failure or shutoff

These or other faults are stored. If the cause of the fault has been eliminated, the motor cannot run unless the fault memory has been reset from outside.

The following functions have been realized for the monitoring or protection of the machine:

- limit switch functions
- I²t current limiting

Functions of the Servo Amplifiers

Operating modes

TrioDrive D servo amplifiers can be used in a wide range of applications. For that, different operating modes such as torque mode, electronic gearing, or program operation can be selected via software. There are two large groups of operating modes:

- command mode and
- program mode (option)

Command mode

In command mode, individual movements can be specified via different interfaces. In this mode, the following axis operating modes are available as sub-modes:

- torque mode
- velocity mode
- target position mode (absolute or relative)
- homing mode
- electronic gearing (includes synchronization and pilot frequency)
- flying shear (option)

In these axis operating modes, one of the following interfaces can be selected as setpoint source:

- analog input (axis operating modes torque and velocity)
- input axis coupling, pilot frequency modes (axis operating modes electronic gearing and flying shear)
- a communication interface
 - serial interface COM1 (RS 232C, optionally RS 485), or
 - fieldbus interface (optional)

The behavior of the drive in the different axis ope-

rating modes can be adapted to the application via machine data. Thus, e. g. acceleration and deceleration ramps can be set independent of each other (with trapezoidal or $\sin^2(t)$ ramps, if required); any gear ratio with a high value range can be selected for electronic gearing.

Program mode

The program mode is available as an option. For that, a positioning control is integrated into the device running a part program which can communicate with other controls via various interfaces. This can be used to integrate the drive in the total function of the machine. The part programs consist of single lines, also called blocks. The part program memory has a capacity of 500 blocks on which any number of part programs can be distributed.

The block type determines the function of the individual block. Essential block types in the part program are:

- positioning
- feedforward
- machine functions (set outputs)
- going to home position
- jump to label
- jump on input (bit pattern)
- wait for input (bit pattern)
- program part repetition
- jump to/return from subroutine

The values for position, speeds, etc. can either be defined directly in the block or via variables which can be changed at any time via the communication interfaces.

Part programs can be written comfortably with the SPP Windows software.

Machine data

The parameters of the drive are set via so-called machine data. These data are stored in the servo amplifier in a way that they are protected against power failure. The machine data include e. g.:

- axis type (linear, round, continuous)
- motion profile type (linear, \sin^2) and slope
- factors for adapting position and speed values to physical units (e. g. μm , m/min)
- control-loop parameters
- software limit switches

- in-position window
- behavior of control outputs

Most machine data can be changed during operation via the communication interfaces, e. g. for adapting ramps or controllers to different operating conditions.

Communication

Fieldbus: Interbus, CANopen, or Profibus DP

A field bus interface (Interbus remote bus, CANopen, or Profibus DP) is available as an option. All parameters of the servo amplifier can be transmitted via the fieldbus interface:

- control and status information
- setpoints and actual values
- machine data
- part programs
- variables

The dynamically changing parameters (control and status information, setpoints and actual values) are transmitted cyclically via the process data channel of Interbus, CANopen, or Profibus DP. For sending as well as for receiving, up to 18 byte (Interbus) or 16 byte (Profibus DP) are available. For CANopen, 5 PDO objects are pre-defined for sending and receiving, each. The remaining parameters are transmitted via the parameter channel of Interbus (PCP), CANopen (SDO), or Profibus DP.

DRIVECOM profile 22

Common parameters of a positioning drive were standardized by the DRIVECOM user group in profile 22. ESR was actively involved in the development of this standard, and the TrioDrive D servo amplifiers have been developed according to this profile. The DRIVECOM profile 22 is used for all fieldbus interfaces. This guarantees a standardized parameter access independent of the bus system.

Serial interface

All parameters of the drive can be transmitted via the serial interface. For that, the DRIVECOM profile 22 parameters are used there, as well. Therefore, users working only with the serial interface at the beginning can make use of the knowledge acquired

there in case of a future application of a fieldbus.

Sercos interface

This interface is in preparation. If required, please contact ESR.

Commissioning and Software

The TrioDrive D servo amplifier is delivered ready for operation. For commissioning, a PC can be connected via serial interface COM1 or the optional fieldbus interface. For information on supported fieldbuses and PC connection modules, please contact ESR.

Command and commissioning software SPP Windows

The SPP Windows software was developed for easy operation and commissioning of the servo drives by means of a personal computer (for Windows 95/98/NT 4.0/2000/XP). With it, machine data and part programs can be entered and changed. For commissioning purposes, the drives can be controlled in all operating modes. Control-loop parameters can be set comfortably using oscilloscope functions. Options for archiving and documenting data complete the scope of functions.

Easy operation is ensured by standard Windows features. Frequently needed functions can be selected via hotkeys. The menu structure is based on the standard of VDI/VDE guideline 2186 "Uniform user interface for drive control devices".

The same parameters are used always (DRIVE-COM profile 22), irrespective of the interface.

Function blocks

Function blocks for Siemens Simatic S7 and controllers according to IEC 61131-3, e. g. Bosch Opcon or Schleicher Prosycon, are available for easy integration of the servo drives into automation systems (other controller types on request). The function blocks are based on PLCopen specification "Function blocks for motion control".

Supported functions:

- parameterization of the servo drives by the control (e. g. after switch-on)
- triggering of movements (relative/absolute positioning, going to home position, speed setting, ...)

- influencing the positioning control integrated in the drive (part program)
- input and output of binary signals (software inputs/outputs)

Example programs for using the function library can be used as a basis for the development of own programs.

Drivers, DLL libraries, and example programs

Drivers and DLL libraries are available for the development of own application programs under Windows 95/98/NT 4.0/2000/XP. Included in the scope of delivery are example programs with documented source code which demonstrates the access to the functions of the TrioDrive D servo amplifier via serial interface COM1 and can be used as a basis for own developments.

Accessories

- Motor chokes (for long motor supply cables)
- Motor supply cables and encoder connection cables (also available as ready-assembled cables)
- Connector sets consisting of the required SUB-D male or female connectors, including screwable housings, and the Combicon connectors
- External shunt resistor (for special applications in which the internal shunt resistor is not sufficient)

Detailed information on ESR products and the corresponding accessories are also available in the internet on www.esr-pollmeier.de.

Drive Packages (Selection), Important Technical Specifications, and Order Numbers

In addition to the motors listed below, a lot of other motors are available. Detailed information can be found in separate data sheets and in the internet on www.esr-pollmeier.de.

Flange Dimension (mm)	Order Number Motor	Speed (rpm)	Rated Torque (Nm)	Stall Torque (Nm)	Peak Torque (Nm)	Shaft Power (kW)	Order Number Amplifier
55	MR 4045-U3-N060-L0..	6000	0.5	0.6	2.3	0.3	BN 6751
	MR 4060-U3-N060-L0..	6000	0.7	0.8	2.8	0.4	BN 6751
74	MR 4104-U3-N060-L0..	6000	0.5	0.7	2.2	0.3	BN 6751
	MR 4108-U3-N060-L0..	6000	1.0	1.4	3.2	0.5	BN 6752
92	MR 4606-U3-N034-L0..	3400	2.4	2.5	8.8	0.9	BN 6752
	MR 4608-U3-N034-L0..	3400	4.4	4.6	16.0	1.6	BN 6753

The rated torques refer to the stated speed. At lower speeds, the torques are higher. We recommend to choose the best combination for your application together with us. We will be pleased to calculate and configure the drive system in cooperation with the customer.

Servo Amplifiers, Important Technical Specifications, and Order Numbers

Servo Amplifier	BN 6751	BN 6752	BN 6753 *
Rated supply voltage (50 .. 60 Hz)	230 V AC \pm 10%		
Rated DC-bus voltage	320 V DC		
Rated current (rms)	2 A	4 A	6 A
Pulse current (crest value)	5.5 A	11 A	17 A
Rated electrical power	0.75 kVA	1.5 kVA	2.2 kVA
Max. possible motor power	0.5 kW	0.7 kW	1.1 kW
Switching frequency of power circuit	16 kHz		
Control supply voltage	24 V DC \pm 20%, 0.8 A		
Width	85 mm		
Height (without mounting straps)	175 mm		
Height (with mounting straps)	195 mm		
Depth without connectors	200 mm		
Weight	2.4 kg		

* Amplifier BN 6753 (6 A device) may be operated up to a loading of 70% without restrictions. For a higher loading, the device must be installed next to a control cabinet fan or equipped with a sub-assembled fan.

Type codes of the servo motors are included in the separate data sheets of the respective motors, they are also available in the internet on www.esr-pollmeier.de.

Type Code of the TrioDrive D Servo Amplifiers

Example ⇒ **BN 6751.3500-B1-R1-G0-A1-F0-S0**



51

Mains connection and DC-bus voltage

- 51 mains connection 230 V 1-phase, corresponds to 320 V DC-bus voltage; output current 2 A_{rms}
- 52 mains connection 230 V 1-phase, corresponds to 320 V DC-bus voltage; output current 4 A_{rms}
- 53 mains connection 230 V 1-phase, corresponds to 320 V DC-bus voltage; output current 6 A_{rms}

3500

Assembly code

Internal coding of ESR, given for various feature combinations. Statement of the assembly code is not required if all other features unequal zero are stated and the customer-specific equipment is described. For above-mentioned example, "BN 6751-B1-R1-A1" would be sufficient.

B1

Operating modes

- B1 command mode with torque, speed or position control (standard)
(setting via communication interfaces, alternative setting of torque or speed via analog interface)
- B2 as B1, additionally program mode with positioning control, 500 blocks
- B3 as B2, additionally flying shear

R1

Motor position sensor

- R1 resolver (standard)
- R2 Sincos (Hiperface) encoder (single- or multi-turn)
- R3 high-resolution incremental encoder Heidenhain ERN 1185 or ERN 1387
- R4 EnDat encoder (single- or multi-turn)
- RK customer-specific

G0

Output or input encoder signals

(options Gx and Lx exclude each other, they use the same connector)

Output encoder signals (encoder emulation)

- G0 none (standard)
- G1 incremental encoder output 5 V, push-pull signals RS 422
- G2 incremental encoder output 24 V

L0

Input encoder signals for axis coupling (synchronization, electronic gearing, flying shear), external position sensor or pilot frequency; incremental encoder signals (pulse/direction signals on request)

- L1 signal level 5 V, push-pull signals RS 422
- L2 signal level 24 V

A1

Digital inputs/outputs

- A1 8 inputs, 4 outputs (24 V) (standard)
- AK customer-specific

F0

Fieldbus connection

- F0 none (standard)
- F2 CANopen (CAN according to CANopen standards and DRIVECOM profile 22)
- F4 Sercos interface (in preparation)
- F5 Profibus DP according to DRIVECOM profile 22
- F6 Interbus (remote bus) according to DRIVECOM profile 22

S0

Special equipment

- S0 none (standard)
- SK customer-specific



CANopen



The statements in this data sheet are for information, only. They do not guarantee properties. We reserve the right to make changes without notice.

Data Sheet 6750.250 V 2.1a, 2003-12-11 KS